



MODIFIED - 2012

Revised November, 2011. Revisions/clarifications underlined. *recommendations italicized*. Refer to www.imca.com for General Rules.

IMCA
1800 West D Street
P.O. Box 921
Vinton IA 52349-0921
319-472-2201 24-hour fax 319-472-2218
www.imca.com
raceimca@imca.com

The rules and/or regulations set forth herein are designed to provide for the orderly conduct of racing events and to establish minimum acceptable requirements for such events. These rules shall govern the condition of all events, and by participating in these events, all participants are deemed to have complied with these rules. NO EXPRESSED OR IMPLIED WARRANTY OF SAFETY SHALL RESULT FROM PUBLICATIONS OF OR COMPLIANCE WITH THESE RULES AND/OR REGULATIONS. They are intended as a guide for the conduct of the sport and are in no way a guarantee against injury or death to a participant, spectator or official.

The race director shall be empowered to permit reasonable and appropriate deviation from any of the specifications herein or impose any further restrictions that in his opinion do not alter the minimum acceptable requirements. NO EXPRESSED OR IMPLIED WARRANTY OF SAFETY SHALL RESULT FROM SUCH ALTERATION OF SPECIFICATIONS. Any interpretation or deviation of these rules is left to the discretion of the officials. Their decision is final.

- SAFETY EQUIPMENT:** Rules apply at all times car is on track. Snell-rated SA2000, SA2005 or SA2010 helmet required. Roll bar padding required in driver compartment (*Fire retardant recommended*). SFI-approved full fire suit required. Fire retardant gloves, shoes and neck brace (or head and neck restraint) required. Right and left seat head supports required if using head restraint system with no neck collar. *Recommended: Fire retardant head sock and underwear; collapsible steering shaft.* Driver-side window net required, minimum 16 inch by 20 inch ribbon or mesh style, and must be mounted to roll cage so latch is at top front of window. Minimum three inch (two-inch with head restraint system) wide SFI-approved five point safety belt assembly required (Y-type shoulder harness not allowed), must be mounted securely to roll cage, *recommended to be no more than two years old*. Kill switch required within easy reach of driver and must be clearly marked 'OFF' and 'ON'.
- FRAME:** 1964 or newer OEM perimeter American rear-wheel drive passenger car frame only. No sports car frames. Frame must be full and complete, cannot be widened or narrowed, and must be able to support roll cage on both sides, exceptions are: weight jack in original center line of spring tower allowed; frame may be cut a maximum 36 inches forward from center of rear end housing; horns may be removed in front of steering box and notched maximum one inch at bottom for tie rod clearance; front crossmember may be notched and boxed for radiator and/or steering clearance; maximum seven inch wide opening in side of spring tower for spring removal. Maximum two inch wide by four inch tall frame stiffener may be welded directly to outside of left side frame rail. See www.imca.com for OEM frame dimensions. Minimum wheelbase 108 inches, maximum 112 inches, both sides. Maximum overall width shall not exceed 78 inches from outside of tire to outside of tire. No part of frame can be lower than four inches from ground except front crossmember.
- ROLL CAGE:** Must consist of continuous hoops, minimum 1.75 inch O.D. tubing, with minimum wall thickness of 0.095 inch for main cage, frame-mounted in at least six places, *low carbon or mild steel recommended*. Must consist of a configuration of front, rear and top hoops connected by tubing on sides or side hoops. Driver's head must not protrude outside cage with helmet on. Roll cage must be securely supported and braced with minimum one cross bar in top halo. Foot protection bar required. Main cage no further forward than rear of engine. All bars forward of cage must be lower than hood.
- DOOR BARS:** All driver side door bars and uprights must be minimum 1.5 inch O.D. with 0.083 inch wall thickness. Minimum three driver side door bars, parallel to ground and perpendicular to driver, and welded to front and rear of roll cage. Passenger side must have at least one cross door bar, horizontal or angled, minimum 1.25 inch O.D. with 0.083 inch wall thickness, and one top door bar, minimum 1.5 inch O.D. with 0.083 inch wall thickness. Steel door plate, 18 gauge or 0.049 inch minimum thickness, must be securely welded to outside of driver side door bars and cover area from top door bar to bottom door bar and from rear hoop down-post to five inches in front of seat. Must be visible for inspection.
- BODY:** (See diagram) No composite or plastic body panels allowed except roof rock guard and hood scoop. Body must be same width, front to rear, and parallel to OEM frame. Aluminum nose panel must be flat. Maximum 2.250 inch side fins allowed on aluminum nose. MD3 plastic nose piece, part #020-410 allowed. All nose panels may be no wider, or lower than two inches outside of front frame horns and remain within 0.5 inch tolerance outside confines of front bumper. Plastic nose must be mounted in an approved manner and can extend no further back than 6 inches from front of hood. Cooling holes allowed. Engine compartment must remain open (no side panels). Hood must be level or sloped down at front, enclosed and maximum two inches above interior deck at rear. No reverse hood rake allowed. No panel in front of right door to engine compartment. No inner panels. No car covers. Must have front and rear roof support posts. Driver and passenger side windows must have at least 12 inch opening (height and width), measured at center of window, between lowest point at top and highest point at bottom. Sail panels may not extend ahead of back of seat. May use Lexan in sail panels. Roof must be fiberglass or aluminum, full size and rounded down in all directions (see diagram). No dished roofs allowed. Driver roof hatch allowed. Maximum 1.5 inch rolled down rock guard allowed on roof front. Maximum four inch roof sides allowed. Maximum one inch ridge down sides of roof. Maximum one inch rear roof stiffener (must face down). No fins, lips, wings or spoilers. Maximum four inch plastic skirting allowed on bottom of doors and quarters. No reflective doors or quarter panels. Body may be maximum one inch outside of rear tires (both sides) for clearance. Car number must be minimum four inches thick and 20 inches tall and clearly visible, on both sides, top and back of car, and front, if possible.
- DRIVER COMPARTMENT:** Must have minimum three windshield bars in front of driver. Lexan or aluminum cowl panel in front of driver can be no wider than cockpit and no farther back than steering wheel. Minimum 0.125 inch aluminum, or 0.060 inch steel, complete floor pan required. Aluminum high-back seat only and must be bolted in, using minimum 0.375-inch bolts, next to left side frame rail and ahead of rear tires. Bottom of seat can be no lower than bottom of frame rail. Driver must be sealed off from track, driveline, engine, fuel cell, cannisters and pumps. Oil coolers must not protrude above interior. Accumulators cannot be mounted between driver and left-side door bars. No driver-adjustable devices allowed while car is in competition except brake adjuster. No mirrors of any kind.
- FRONT SUSPENSION:** All components must be steel, unaltered OEM, in OEM location, and replaceable by OEM parts, exceptions are: tube-type upper A-frames with or without aluminum or steel cross shaft, and mounts can be moved; stamped steel OEM replacement lower A-frames; rubber, nylon or steel lower A-frame bushings, no offset or bearing type; welded or bolted shock mount on lower A-frame; OEM or OEM replacement ball joints allowed. Lower A-frames must be right and left, and of same design. Lower A-frame mounts and bolt holes on frame must be within OEM specifications. Sway bar must be unaltered OEM. No bump stops of any kind allowed.
- STEERING:** No rack and pinion. All components must be steel, unaltered OEM, in OEM location, exceptions are: outer tie rod end and adjustment sleeve may be replaced by a minimum 0.625 inch steel rod end and steel tube; spindles can be ground for brake caliper clearance only; unaltered, OEM or OEM replacement Pinto spindles with 'IMCA' raised cast; bolt on spindle savers allowed; steel steering shafts and knuckles only; driver compartment steering may be modified, must be kept on left side. Spindles must be right and left, and of same design. Quick release required - steering quickener and steering wheel may be aluminum. Idler arm, pitman arm, and center link must match frame.
- SHOCKS:** One steel, nonadjustable, unaltered shock per wheel. One additional shock allowed in lift- or pull-bar area. No external or internal bumpers or stops. No threaded body, front coil-over, air, or remote reservoir shocks. No Schrader or bladder type valve allowed. Front half may be shielded. One or all shocks may be claimed per event for \$50 each, counting as one claim on card, following shock claim procedures (Refer to www.imca.com).
- SPRINGS:** One steel, non-progressive coil spring per wheel only. One additional spring allowed on pull bar, may be progressive. All coil springs must be at least 4.5 inches O.D. No torsion bars, air bags, inner liners or spring rubbers allowed. Steel or composite leaf spring allowed.
- REAR SUSPENSION:** No independent rear suspension. All components must be steel. No covers allowed. All trailing arms/link bars must be solid tubing. Rear of frame may be altered to accept leaf or coil springs. Steel coil-over eliminators, or steel or aluminum coil-over kits allowed - must conform to shock and spring rules. One mechanical traction pull bar allowed. No lift, brake or sway bars. Rubber bumpers allowed pull bar or panhard bar only. Solid safety chains, cables or tethers permitted frame to axle housing only (cannot be mounted to any floating device), no springs or rubbers allowed. Minimum 19 inch long panhard bar, measured straight line, center to center.
- REAR END:** Any steel approved OEM passenger car or truck rear end (housing and carrier) allowed. Safety hubs (floater) allowed. All components must be steel, except lowering blocks, axle cap, drive flange. Inspection hole required in housing. Full steel spool, steel mini spool or welded rear ends only. Steel axles only. No quick change devices, or cambered rear ends. One piece drive flange only. No torque dividing differentials. No scalloped ring gears.
- BUMPERS:** (See diagram) Steel bumpers must be on front and rear at all times and welded, or mounted with minimum 0.375 inch bolts. Rear bumper must be constructed of solid square, or minimum 1.25 inch O.D. tubing with 0.095 wall thickness (similar to diagram), maximum six inches beyond rear deck, no wider than five inches outside of rear frame rails. If wider than five inches outside rear frame rails, must be capped and bent forward 90 degrees, or constructed in a loop design. Must have at least one upright, minimum 1.25 inch with 0.065 wall thickness, from bumper to fuel cell guard. Two-bar front bumper must be minimum 1.25 inch O.D. tubing with minimum 0.065 wall thickness (maximum 0.095 inch) mounted frame-end to frame-end, no wider than width of material outside frame horns and with bottom loop parallel to ground. Top bar must be directly above bottom bar, minimum 6.5 inches apart, measured center to center.
- TIRES/WHEELS:** Must use unaltered Hoosier Race tire, G60-15 with IMCA stamped on sidewall. No chemical softening, conditioning, or grooving of tires (refer to www.imca.com for automatic penalties). Tires may be ground or siped within confines of tread (not past factory straight line). No re-caps. All wheels must display white 'IMCA approved' decal and wheel manufacturer decal. Aluminum, composite or steel spacers allowed. May use IMCA approved bead lock, on right rear only. External, steel bead lock only and it cannot make wheel any narrower than 8 inches and no wider than 8.75 inches. Must use only steel bolts. Foam type or plastic outer mud cover allowed on right side wheels. Inner mud cover allowed on left rear only. Rim-mounted bleeder valves allowed. Steel lug nuts only.
- BRAKES:** Must be steel approved OEM, operative four wheel, drum or disc. Must maintain minimum OEM dimensions for hubs/rotors and calipers, cannot be lightened. Bolt pattern may be changed. Larger studs allowed. Rear rotors may be aftermarket 0.81 inch thickness (new). Vented rotors only, no scalloped or ceramic coated rotors. No brake shut-off or pressure sensitive devices. One front to rear proportioning device allowed. Brake lines must be visible.
- EXHAUST:** Round tube headers only. All primary header tubes must enter directly into one collector at same point at end of header. Schoenfeld mufflers, stamped IMCA609, must be used if track has noise reduction rule of 98 d.b. or more (exception is California). Extreme Muffler part # 1014-3030, or part # 1114-3535, are highly recommended for tracks that require noise reduction of 97 d.b. or less. All exhaust must go through mufflers, two per car, one per header. No merge collectors. No exhaust sensors. Pan-evac system allowed.
- FUEL SYSTEM:** Mechanical or belt driven fuel pump only and must be mounted at front of engine. Racing fuel cell required, maximum 32 gallon capacity, must be in minimum 20 gauge steel container. Cell must be securely mounted behind rear axle, between rear tires, minimum of four inches ahead of bumper, minimum of ten inches above ground. Must mount with minimum two solid steel straps around entire cell, two inches wide and 0.125 inch thick. All cell mounts must be steel, securely welded to frame/cage. Protective tubing must cover rear and extend past both sides of cell. No part of cell shall be lower than protective tubing. Fuel cell vents, including cap vent, must have check valves. If fuel cell does not have aircraft style positive seal filler neck/cap system - a flapper, spring or ball type filler rollover valve is required. Pick-up must be on top or right side of cell. Limit of one fuel filter. No cool cans. Air cleaner top/stud cannot direct air into carburetor. No top flow air cleaner housings or cold air boxes. One naturally aspirated two- or four-barrel carburetor only. One carburetor adapter/spacer allowed, maximum 2.20 inches thick, including gaskets. No adjustable throttle bore carburetor spacers.
- FUEL:** Gasoline or alcohol. Racing fuel allowed. NO performance-enhancing additives. Upper cylinder lube allowed with alcohol only. (Refer to www.imca.com for

automatic penalties).

- 19. WEIGHT:** Minimum weight limit of 2,450 pounds, no tolerance, after race with driver in car. No weights and/or loose objects in driver compartment, above interior deck or outside body. Weights must be securely mounted to frame or roll cage and painted white with car number on it. Must be attached with at least two 0.5 inch bolts. No titanium, magnesium or carbon fiber products. Only carbon fiber components allowed are rock guard and hood scoop. No gun-drilled, tubular, hollow bolts or studs. Steel fasteners only.
- 20. BATTERY/STARTER:** One 12 volt battery only, must be securely mounted between frame rails, and positive terminal must be covered. Car must have capability of starting without being pushed or pulled. Car must leave initial staging area on demand, unaided, or go to rear of that race. Reverse-mount starters with OEM case transmissions only, see transmission rules for specifics.
- 21. GAUGES/ELECTRONICS:** No unapproved cameras, transmitting or listening devices (exception is one-way RACEceiver radio by officials), timing retard controls, or digital gauges (including tach). No electronic monitoring computer devices capable of storing or transmitting information except memory recall analog tach. All cars MUST use max 7,800 rpm rev limiter chip. This may be accomplished using one, non-adjustable, 12 volt ignition box with one high-end rev-limiter setting or an internal setting inside box. MSD #8728 rev-control or MSD #8738 additional rev control box allowed. Preset Crane #6000-6478 ignition box allowed. No additional ignition accessories allowed. All components must be out of reach of driver, but accessible for inspection. No magnetos or crank triggers. No electronic traction control devices (Refer to www.imca.com for automatic penalties).
- 22. TRANSMISSION/DRIVESHAFT:** Must have at least two forward gears and one reverse, plus a neutral position. With engine running and car in still position, must be able to engage car in gear and move forward, then backward. OEM production type or IMCA approved aftermarket transmissions allowed - two-speed, three-speed, four-speed and automatic. No five speed (or more) transmissions, 'in and out' boxes, or quick change devices allowed. Functioning shift levers must be in OEM location on all OEM production type transmissions. All belt drive pumps must be mounted on front of engine. Flexplates must be full, steel, unaltered OEM, or OEM replacement. Flywheel/flexplate must bolt to engine between clutch assembly and crankshaft and all driveline components within bellhousing must rotate while car is in any gear. Transmission must be one of the following designs:
OEM Manual: Must have a standard OEM case and working disc-type clutch or approved cone or disc-type coupler inside an explosion-proof steel bellhousing. One flywheel only, minimum 8.5 inch diameter. Diameter of clutch disc must be a minimum of 5.5 inches. Clutch assembly must be steel, except housing, which must be steel and/or aluminum. Bellhousing can have only a hole for throwout bearing lever or hose, must be 270 degrees around top of clutch and flywheel area. Standard or reverse mount starter allowed, must directly engage flywheel.
Automatic: Must remain in OEM or OEM replacement case, with a functioning OEM appearing pump. Aluminum OEM bellhousing may be replaced with aftermarket explosion-proof aluminum bellhousing. Original OEM bellhousing must have approved scattershield constructed of minimum 0.125-inch by three-inch steel, 270 degrees around flexplate.
Aftermarket Manual: Must be IMCA approved, aluminum case, with internal clutch. Must bolt to explosion-proof steel bellhousing, and use full, steel, unaltered OEM or OEM replacement flexplate with starter mounted in OEM location. No coatings or paint allowed on transmission case.
Drive Shaft: Minimum two inch diameter steel drive shaft and must be painted white. Steel slip-yokes only. 360-degree drive shaft loop required and must be constructed of at least 0.25 inch by two inch steel, or one inch tubing, mounted six inches back from front U-joint.
- 23. ENGINE COMPARTMENT:** Rear of engine (bellhousing flange) must be mounted at least 72 inches forward from centerline of rear axle. Engine offset must be kept within two inches of centerline of front crossmember with engine level. Minimum 11 inch engine height from ground to center of crankshaft. Radiator must be mounted in front of engine. Cooling system may be modified. Overflow tubes must be directed to ground between frame rails.
- 24. ENGINE SPECIFICATIONS:** Any American make steel engine block allowed. Aftermarket and OEM performance blocks allowed. Cast iron or aluminum intake manifolds only. Steel cylinder heads and oil pan only. Flat tappet cam/lifters and stud-mounted rocker arms only. Magnetic steel retainers only. No shaft or pedestal rocker arms, titanium engine components, stud girdles or mushroom lifters. Lifter diameter and configuration must match OEM passenger block. OEM firing order cannot be changed (GM: 1-8-4-3-6-5-7-2). All engines must be able to be used in conventional passenger car without alterations. Engine mounts cannot be removed or altered. Castings and fittings must not be changed. No machine work on outside of engine (no lightweight engine blocks). All belt driven accessories must be on front of engine. 'Wet' sump oiling system only. External oil pumps go with engine if claimed.
- 25. ENGINE CLAIMING RULES:** Refer to www.imca.com for claim eligibility requirements.
 (A) \$1,050 cash, or \$100 and exchange, claim on engine, flywheel and balancing plates (\$25 goes to wrecker and \$25 to official for each engine). Claimed driver has option of accepting cash, or exchanging engines with claiming driver.
 (B) Claim does not include - 1. clutch, 2. pressure plate, 3. bellhousing, 4. headers, 5. carburetor, 6. starter, 7. motor mounts, 8. oil/temp. sending units, 9. carburetor spacer, 10. fan and pulleys, 11. clutch ball, 12. clutch arm, 13. throw out bearing, 14. dip stick, 15. water pump, 16. fuel pump, rod and plate, 17. distributor, 18. plug wires, 19. water outlet and restrictor, 20. breathers.
- 26. POINT STRUCTURE/PROCEDURES:** Refer to www.imca.com for automatic penalties.
- 27. EIRI:** (Except in rare instances) Decisions of IMCA Officials are final and binding without exception. In some cases, track safety rules may take precedence over IMCA rules - any discrepancy between IMCA and track rules should be brought to the attention of IMCA. Any rule changes or clarifications during the course of the year will be amended at www.imca.com as well as published in **Inside IMCA**, the official newsletter of IMCA, and will be considered as an official part of these rules.

For more information, call Tom Gutowski at 402-350-6120 or IMCA at 319-472-2201.

Copyright© 2012 IMCA. All rights reserved.

No part of this publication may be reproduced, stored, or transmitted in any form, without prior written permission.

IMCA Modified Body Dimensions For 2012

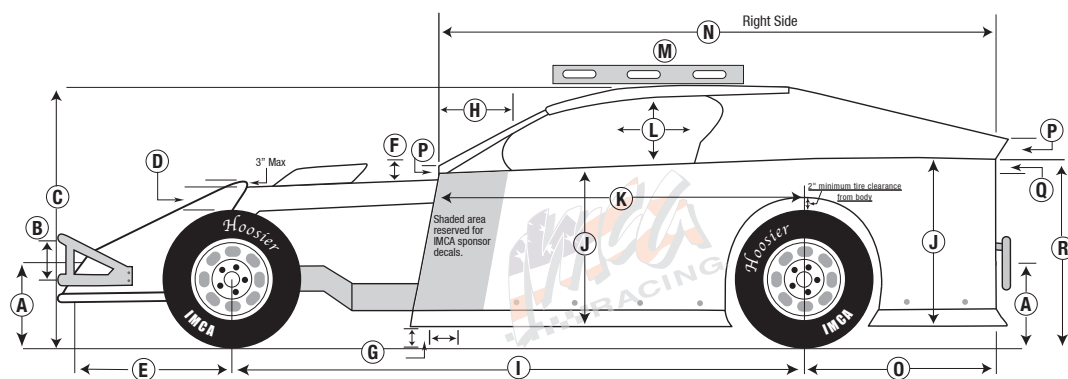

All body measurements are max. unless otherwise specified. Dimensions have zero tolerance.

- A** 20" max. 16" min. (ground to center of bumpers, front and rear)
B 6.5" min. (center to center)
C 54" max. 42" min.
D Hood 6" max. drop (sides), sealed off from driver's compartment and max. 3" rake.
E 42" max.
F 6" max. scoop cannot extend past front of hood.
G 4" minimum; Door may extend maximum 6" past block at bottom on both sides.
H 19" max., must be same on both sides.
I 112" max. 108" min.
J 31" max. 22" min.
K 72" max. or not past back of block at top. Left side may extend forward to cover foot box if necessary.
L 18" max. 12" min. opening, both sides.
M With level, must have no more than 2" clearance at rear of roof and 5" at top front.
N 120" max. 106" min.
O 48" max. 34" min.
P 4" max. at front and rear, gradual slope from roof to this point. See drawing for tolerances.
Q Interior slope is 6" max. front to rear and flat across. If flat at front half of interior you have used up 50% of your 6" so from behind driver to rear you may only have 3". Top of interior must be flush with top of door and quarter panels. An optional escape hatch from driver to passenger door to provide 12" opening allowed.
R 38" max. 28" min.
S Min. 24" nose must be flat and flush with sides.
T 66" max. 24" min., no narrower than radiator.
U 52" max. 44" min.
V 56" max. 41" min.
W Tires max 1" inside body both sides.
X 66" max. 53" min. measured at top of interior deck, must be same front to back.
Y IMCA decal required on filler panel.
REAR FILLER PANEL: 8" min. / 90 degree angle. Must be solid, attached to deck, extend to quarter panels, securely fastened.
SAIL PANELS: Must extend from roof to rear of car and be the same on both sides. May extend 2" maximum past rear edge of interior deck. Must mount within 2" of outside edge of interior deck.

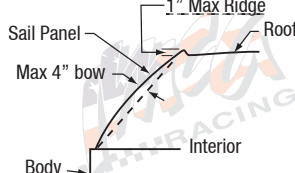
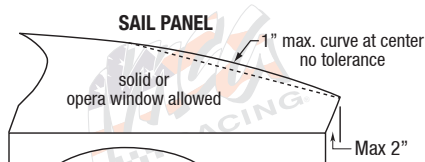
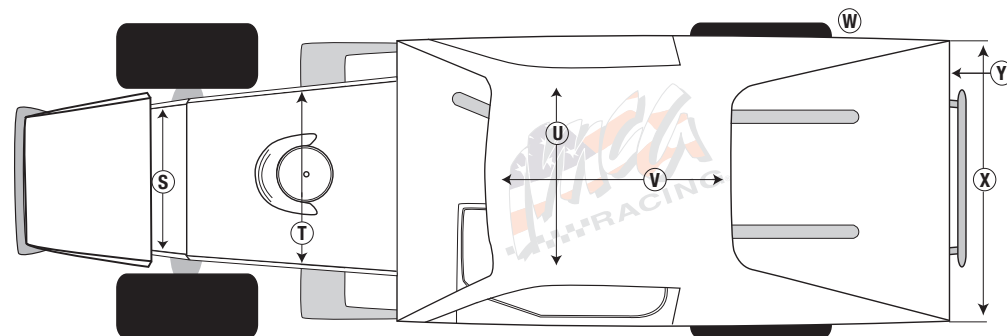

©2012 BY IMCA